



KERN & Sohn GmbH

Ziegelei 1
D-72336 Balingen
E-Mail: info@kern-sohn.com

Tel: +49-[0]7433- 9933-0
Fax: +49-[0]7433-9933-149
Internet: www.kern-sohn.com

Operating instruction Platform scale

KERN DE

Version 4.0
12/2006
GB



DE-BA-e-0640



KERN DE

Version 4.0 12/2006

Operating instruction

Platform scale

Table of Contents

1	Technical data	4
2	Declaration of conformity	11
3	Basic Information (General)	12
3.1	Proper use	12
3.2	Improper Use	12
3.3	Warranty.....	12
3.4	Monitoring of Test Resources.....	13
4	Basic Safety Precautions.....	13
4.1	Pay attention to the instructions in the Operation Manual.....	13
4.2	Personnel training.....	13
5	Transport and storage	13
5.1	Testing upon acceptance	13
5.2	Packaging	13
6	Unpacking, Setup and Commissioning.....	14
6.1	Installation Site, Location of Use.....	14
6.2	Unpacking.....	14
6.2.1	Setup	14
6.2.2	Scope of delivery	14
6.2.3	Grundaufbau.....	15
6.2.3.1	Assembly instructions for the use of the tripod (option)	15
6.3	Mains connection	16
6.4	Operation using a (rechargeable) battery (optional).....	16
6.5	Connection of peripheral devices.....	16
6.6	Initial Commissioning.....	17
6.7	Adjustment	17
6.8	Adjustment	17
7	Operation	18
7.1	Overview of display.....	18
7.2	Weighing	18

7.3	Taring	19
7.4	PRE-Tare function	19
7.5	Plus/minus weighings.....	19
7.6	Parts counting	20
7.7	Net-total weighings	20
7.8	Percent weighings.....	21
7.9	Weighing units (Unit)	22
7.10	Display background illumination	24
7.11	Animal weighing function.....	25
8	Settings	26
8.1	Call-up menu structure	26
8.2	Leave menu structure	27
8.3	Dosing and Zero-tracking.....	27
8.4	Selection of the adjustment weight	28
8.5	Interface RS232C.....	29
8.5.1	Data transfer mode	29
8.5.2	Baud rate	29
8.6	Selection printed edition	30
8.7	Reset to factory setting	31
9	Data output RS 232 C.....	32
9.1	Technical data	32
9.2	Pin allocation of the balance output socket (front view)	32
9.3	Explanation of the data transfer.....	32
9.3.1	Pr PC	32
9.3.2	AU Pr.....	32
9.3.3	AU PC.....	33
9.3.4	rE Cr	33
9.4	Output on bar code printer.....	34
10	Service, maintenance, disposal.....	35
10.1	Cleaning	35
10.2	Service, maintenance.....	35
10.3	Disposal	35
11	Instant help.....	36

1 Technical data

KERN	DE3K1N	DE6K0.5N	DE6K2N	DE12K1N
<i>Readability (d)</i>	1 g	0.5 g	2 g	1 g
<i>Weighing range (max) (d)</i>	3 kg	6 kg	6 kg	12 kg
<i>Taring range (subtractive)</i>	3 kg	6 kg	6 kg	12 kg
<i>Minimum piece weight</i>	2 g	1 g	4 g	2 g
<i>Reproducibility</i>	1 g	0.5 g	2 g	1 g
<i>Linearity</i>	± 3 g	± 1.5 g	± 6 g	± 3 g
<i>Warm-up time</i>	10 minutes	30 minutes	10 minutes	30 minutes
<i>Reference unit weights at piece count</i>	5, 10, 25, 50			
<i>Weighing Units</i>	<i>Details „Weighing units“ chapter 7.9</i>			
<i>Recommended adjustment weight, not added (class)</i> <i>Details for „Selection of the Adjustment weight“ in chapter 8.4</i>	3 kg (M2)	6 kg (M1)	6 kg (M2)	12 kg (M1)
<i>Stabilization time (typical)</i>	3 sec.			
<i>Operating temperature</i>	+ 5° C + 35° C			
<i>Humidity of air</i>	max. 80 % (not condensing)			
<i>Terminal (B x D x H) mm</i>	200 x 100 x 55			
<i>Platform (B x D x H) mm</i>	315 x 305 x 75			
<i>Weight kg (net)</i>	4	4	4	4

KERN	DE15K0.5N	DE15K5N	DE24K2N	DE30K1N
<i>Readability (d)</i>	0.5 g	5 g	2 g	1 g
<i>Weighing range (max)</i>	15 kg	15 kg	24 kg	30.5 kg
<i>Taring range (subtractive)</i>	15 kg	15 kg	24 kg	30.5 kg
<i>Minimum piece weight</i>	1 g	10 g	4 g	2 g
<i>Reproducibility</i>	0.5 g	5 g	2 g	1 g
<i>Linearity</i>	± 1.5 g	± 15 g	± 6 g	± 3 g
<i>Warm-up time</i>	2 hours	10 minutes	30 minutes	2 hours
<i>Reference unit weights at piece count</i>	5, 10, 25, 50			
<i>Weighing Units</i>	<i>Details „Weighing units“ chapter 7.9</i>			
<i>Recommended adjustment weight, not added (class)</i> <i>Details for „Selection of the Adjustment weight“ in chapter 8.4</i>	15 kg (F2)	15 kg (M2)	20 kg (M1)	30 kg (F2)
<i>Stabilization time (typical)</i>	3 sec.			
<i>Operating temperature</i>	+ 5° C + 35° C			
<i>Humidity of air</i>	max. 80 % (not condensing)			
<i>Terminal (B x D x H) mm</i>	200 x 100 x 55			
<i>Platform (B x D x H) mm</i>	315 x 305 x 82	315 x 305 x 75	315 x 305 x 75	315 x 305 x 82
<i>Weight kg (net)</i>	5	4	4	5

KERN	DE36K10N	DE36K10NL	DE60K2N	DE60K5N
<i>Readability (d)</i>	10 g	10 g	2 g	5 g
<i>Weighing range (max)</i>	36 kg	36 kg	60 kg	60 kg
<i>Taring range (subtractive)</i>	36 kg	36 kg	60 kg	60 kg
<i>Minimum piece weight</i>	20 g	20 g	4 g	10 g
<i>Reproducibility</i>	10 g	10 g	2 g	5 g
<i>Linearity</i>	± 30 g	± 30 g	± 6 g	± 15 g
<i>Warm-up time</i>	10 minutes	10 minutes	2 hours	30 minutes
<i>Reference unit weights at piece count</i>	5, 10, 25, 50			
<i>Weighing Units</i>	Details „ Weighing units “ chapter 7.9			
<i>Recommended adjustment weight, not added (class)</i> <i>Details for „Selection of the Adjustment weight“ in chapter 8.4</i>	30 kg (M2)	30 kg (M2)	60 kg (F2)	60 kg (M1)
<i>Stabilization time (typical)</i>	3 sec.			
<i>Operating temperature</i>	+ 5° C + 35° C			
<i>Humidity of air</i>	max. 80 % (not condensing)			
<i>Terminal (B x D x H) mm</i>	200 x 100 x 55			
<i>Platform (B x D x H) mm</i>	315 x 305 x 75	522 x 403 x 100	315 x 305 x 82	315 x 305 x 75
<i>Weight kg (net)</i>	5	16	5	5

KERN	DE60K5NL	DE60K20N	DE60K20NL
<i>Readability (d)</i>	5 g	20 g	20 g
<i>Weighing range (max)</i>	60 kg	60 kg	60 kg
<i>Taring range (subtractive)</i>	60 kg	60 kg	60 kg
<i>Minimum piece weight</i>	10 g	40 g	40 g
<i>Reproducibility</i>	5 g	20 g	20 g
<i>Linearity</i>	± 15 g	± 60 g	± 60 g
<i>Warm-up time</i>	30 minutes	10 minutes	10 minutes
<i>Reference unit weights at piece count</i>	5, 10, 25, 50		
<i>Weighing Units</i>	Details „Weighing units“ chapter 7.9		
<i>Recommended adjustment weight, not added (class)</i> <i>Details for „Selection of the Adjustment weight“ in chapter 8.4</i>	60 kg (M1)	60 kg (M2)	60 kg (M2)
<i>Stabilization time (typical)</i>	3 sec.		
<i>Operating temperature</i>	+ 5° C + 35° C		
<i>Humidity of air</i>	max. 80 % (not condensing)		
<i>Terminal (B x D x H) mm</i>	200 x 100 x 55		
<i>Platform (B x D x H) mm</i>	522 x 403 x 100	315 x 305 x 75	522 x 403 x 85
<i>Weight kg (net)</i>	16	5	16

KERN	DE120K10N	DE120K10NL	DE150K5N
<i>Readability (d)</i>	10 g	10 g	5 g
<i>Weighing range (max)</i>	120 kg	120 kg	150 kg
<i>Taring range (subtractive)</i>	120 kg	120 kg	150 kg
<i>Minimum piece weight</i>	20 g	20 g	10 g
<i>Reproducibility</i>	10 g	10 g	5 g
<i>Linearity</i>	± 30 g	± 30 g	± 15 g
<i>Warm-up time</i>	30 minutes	30 minutes	2 hours
<i>Reference unit weights at piece count</i>	5, 10, 25, 50		
<i>Weighing Units</i>	Details „ Weighing units “ chapter 7.9		
<i>Recommended adjustment weight, not added (class)</i> <i>Details for „Selection of the Adjustment weight“ in chapter 8.4</i>	120 kg (M1)	120 kg (M1)	150 kg (F2)
<i>Stabilization time (typical)</i>	3 sec.		
<i>Operating temperature</i>	+ 5° C + 35° C		
<i>Humidity of air</i>	max. 80 % (not condensing)		
<i>Terminal (B x D x H) mm</i>	200 x 100 x 55		
<i>Platform (B x D x H) mm</i>	315 x 305 x 75	522 x 403 x 100	315 x 305 x 82
<i>Weight kg (net)</i>	5	16	5

KERN	DE150K50N	DE150K50NL	DE150K50NXL
<i>Readability (d)</i>	50 g	50 g	50 g
<i>Weighing range (max)</i>	150 kg	150 kg	150 kg
<i>Taring range (subtractive)</i>	150 kg	150 kg	150 kg
<i>Minimum piece weight</i>	100 g	100 g	100 g
<i>Reproducibility</i>	50 g	50 g	50 g
<i>Linearity</i>	± 150 g	± 150 g	± 150 g
<i>Warm-up time</i>	10 minutes	10 minutes	10 minutes
<i>Reference unit weights at piece count</i>	5, 10, 25, 50		
<i>Weighing Units</i>	Details „ Weighing units “ chapter 7.9		
<i>Recommended adjustment weight, not added (class)</i> <i>Details for „Selection of the Adjustment weight“ in chapter 8.4</i>	150 kg (M2)	150 kg (M2)	150 kg (M2)
<i>Stabilization time (typical)</i>	3 sec.		
<i>Operating temperature</i>	+ 5° C + 35° C		
<i>Humidity of air</i>	max. 80 % (not condensing)		
<i>Terminal (B x D x H) mm</i>	200 x 100 x 55		
<i>Platform (B x D x H) mm</i>	315 x 305 x 75	522 x 403 x 100	650 x 500 x 105
<i>Weight kg (net)</i>	5	16	28

KERN	DE240K20NL	DE300K100N	DE300K100NL
<i>Readability (d)</i>	20 g	100 g	100 g
<i>Weighing range (max)</i>	240 kg	300 kg	300 kg
<i>Taring range (subtractive)</i>	240 kg	300 kg	300 kg
<i>Minimum piece weight</i>	40 g	200 g	200 g
<i>Reproducibility</i>	20 g	100 g	100 g
<i>Linearity</i>	± 60 g	± 300 g	± 300 g
<i>Warm-up time</i>	30 minutes	10 minutes	10 minutes
<i>Reference unit weights at piece count</i>	5, 10, 25, 50		
<i>Weighing Units</i>	<i>Details „Weighing units“ chapter 7.9</i>		
<i>Recommended adjustment weight, not added (class)</i> <i>Details for „Selection of the Adjustment weight“ in chapter 8.4</i>	200 kg (M1)	300 kg (M2)	300 kg (M2)
<i>Stabilization time (typical)</i>	3 sec.		
<i>Operating temperature</i>	+ 5° C + 35° C		
<i>Humidity of air</i>	max. 80 % (not condensing)		
<i>Terminal (B x D x H) mm</i>	200 x 100 x 55		
<i>Platform (B x D x H) mm</i>	522 x 403 x 100	522 x 403 x 85	650 x 500 x 105
<i>Weight kg (net)</i>	16	16	28

2 Declaration of conformity



The electronic balances

Type	KERN DE3K1N	KERN DE30K1N	KERN DE120K10NL
:	KERN DE6K0.5N	KERN DE36K10N	KERN DE150K5N
	KERN DE6K2N	KERN DE36K10NL	KERN DE150K50N
	KERN DE12K1N	KERN DE60K2N	KERN DE150K50NL
	KERN DE15K0.5N	KERN DE60K5N	KERN DE150K50NXL
	KERN DE15K5N	KERN DE60K5NL	KERN DE240K20NL
	KERN DE24K2N	KERN DE60K20N	KERN DE300K100N
		KERN DE60K20NL	KERN DE300K100NL
		KERN DE120K10N	

fulfill the requirements of the following CE guideline:

CE-EMC guideline (directive about electromagnetic compatibility)	in the version 89/336/EWG
--	---------------------------

Applied harmonized standards, in particular:

<p>EN 55022 : 1998 EN 61000-3-2: 1995/A1: 1998/A2 : 1998/A14 :2000 EN 61000-3-3 : 1995 EN 55024 :1998</p>
--

Any modifications of the appliances described above that are carried out without prior permission by **KERN** will render this declaration invalid.

Date: 19.12.2006

Signature:

Gottl. KERN & Sohn GmbH
Management

Gottl. KERN & Sohn GmbH, Ziegelei 1, D-72322 Balingen, Tel. +49-07433/9933-0, Fax +49-074433/9933-149

3 Basic Information (General)

3.1 Proper use

The balance you purchased is intended to determine the weighing value of material to be weighed. It is intended to be used as a “non-automatic” balance, i.e. the material to be weighed is manually and carefully placed in the centre of the weighing plate. As soon as a stable weighing value is reached the weighing value can be read.

3.2 Improper Use

Do not use balance for dynamic weighings. In the event that small quantities are removed or added to the material to be weighed, incorrect weighing results can be displayed due to the “stability compensation” in the balance. (Example: Slowly draining fluids from a container on the balance.)

Do not leave permanent load on the weighing plate. This may damage the measuring system.

Impacts and overloading exceeding the stated maximum load (max) of the balance, minus a possibly existing tare load, must be strictly avoided. Balance may be damaged by this.

Never operate balance in explosive environment. The serial version is not explosion protected.

The structure of the balance may not be modified. This may lead to incorrect weighing results, safety-related faults and destruction of the balance.

The balance may only be used according to the described conditions. Other areas of use must be released by KERN in writing.

3.3 Warranty

Warranty claims shall be voided in case

- Our conditions in the operation manual are ignored
- The appliance is used outside the described uses
- The appliance is modified or opened
- Mechanical damage and damage caused by media, liquids
- Natural wear and tear
- The appliance is improperly set up or incorrectly electrically connected
- The measuring system is overloaded

3.4 Monitoring of Test Resources

In the framework of quality assurance the measuring-related properties of the balance and, if applicable, the testing weight, must be checked regularly. The responsible user must define a suitable interval as well as type and scope of this test. Information is available on KERN's home page (www.kern-sohn.com) with regard to the monitoring of balance test substances and the test weights required for this. In KERN's accredited DKD calibration laboratory test weights and balances may be calibrated (return to the national standard) fast and at moderate cost.

4 Basic Safety Precautions

4.1 Pay attention to the instructions in the Operation Manual

Carefully read this operation manual before setup and commissioning, even if you are already familiar with KERN balances.

4.2 Personnel training

The appliance may only be operated and maintained by trained personnel.

5 Transport and storage

5.1 Testing upon acceptance

When receiving the appliance, please check packaging immediately, and the appliance itself when unpacking for possible visible damage.

5.2 Packaging

Keep all parts of the original packaging in case you need to return the appliance. Only use original packaging for returning. Before sending, disconnect all connected cables and loose/movable parts. Attach possibly existing transport safeguards. Secure all parts, e.g. weighing plate, mains adapter etc., to prevent slipping and damage.

6 Unpacking, Setup and Commissioning

6.1 Installation Site, Location of Use

The balances are designed in a way that reliable weighing results are achieved in common conditions of use.

You will work accurately and fast, if you select the right location for your balance.

Therefore, observe the following for the installation site:

- Place the balance on a firm, level surface;
- Avoid extreme heat as well as temperature fluctuation caused by installing next to a radiator or in the direct sunlight;
- Protect the balance against direct draughts due to open windows and doors;
- Avoid jarring during weighing;
- Protect the balance against high humidity, vapours and dust;
- Do not expose the device to extreme dampness for longer periods of time. Non-permitted condensation (condensation of air humidity on the appliance) may occur if a cold appliance is taken to a considerably warmer environment. In this case, acclimatize the disconnected appliance for ca. 2 hours at room temperature.
- Avoid static charge of goods to be weighed or weighing container.

Major display deviations (incorrect weighing results) may be experienced should electromagnetic fields (e.g. due to mobile phones or radio equipment), static electricity accumulations or instable power supply occur. Change location or remove source of interference.

6.2 Unpacking

Carefully remove the balance from the packaging, remove plastic cover and setup balance at the intended workstation.

6.2.1 Setup

The balance must be installed in a way that the weighing plate is exactly in horizontal position.

6.2.2 Scope of delivery

Serial accessories:

- *Terminal*
- *Platform*
- *Mains power supply*
- *Protective cover*
- *Operating Manual*

6.2.3 Basic structure

- Place the balance on a horizontal and solid base (refer also to „6.2.1 Installation“)
- Pull off the protection foil from the weighing plate if existing.

6.2.3.1 Assembly instructions for the use of the tripod (option)

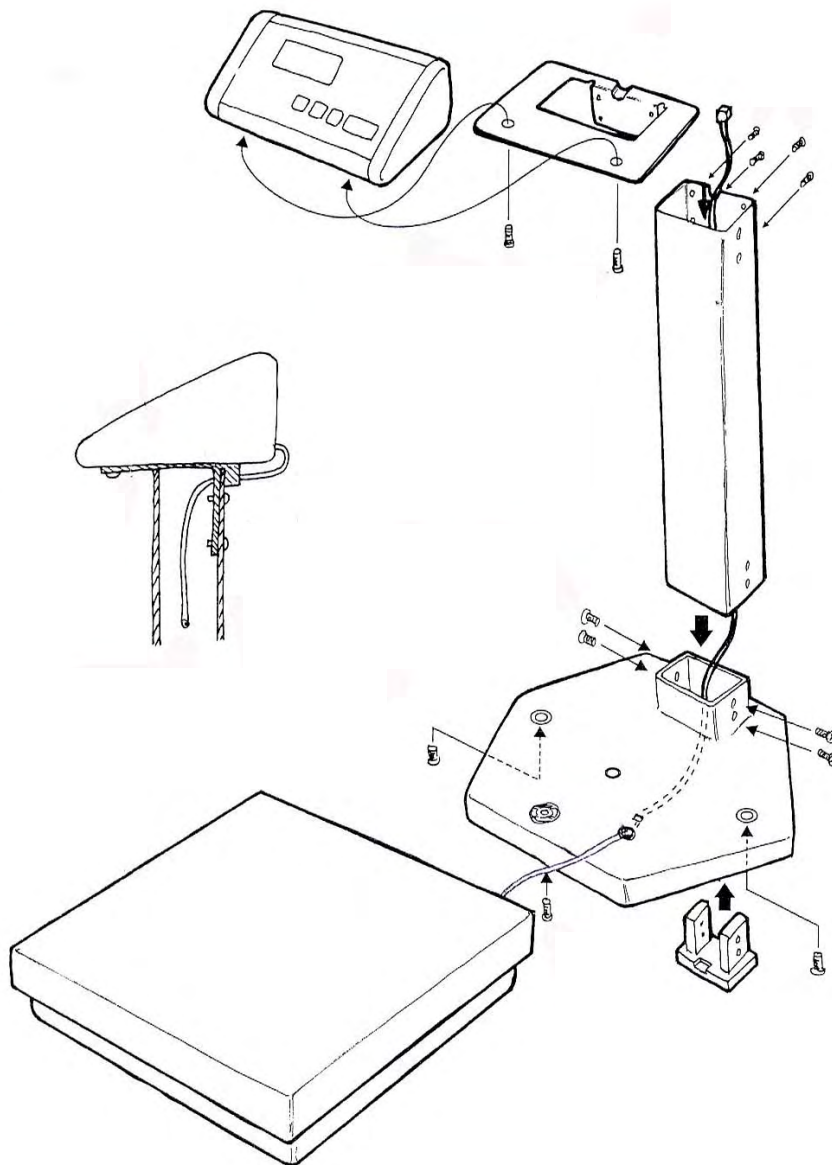

6.3 Mains connection

Power is supplied via the external mains adapter. The stated voltage value must be the same as the local voltage.

Only use original KERN mains adapters. Using other makes requires consent by KERN.

6.4 Operation using a (rechargeable) battery (optional)

Lift-off the battery cover on the lower side of the balance. Connect 9 V compound battery.

Reinsert the battery cover.

For battery operation the balance has an automatic switch-off function which can be activated or deactivated in the menu (chapter 8.1). Proceed as follows:

Switch-on the balance using the  key and wait for the „0“ display.

Press the  key and keep it pressed until „UNIT“ appears on the display.

Press the  key four times, in the display appears „AF“.

Confirm by pressing the  key

Use the  key to choose between the following settings:

1. „AF on“: To save the battery, the balance switches off automatically 3 minutes after having finished the weighing procedure.
2. „AF off“: Switch-off function deactivated.

Use the  key to confirm your selected setting.

If the batteries are exhausted, „LO“ is displayed; press  and replace the batteries immediately.

If the balance is not used for a longer time, take out the batteries and store them separately. Leaking battery liquid could damage the balance.

If there exists an optional rechargeable battery, it has to be connected in the battery compartment via a separate plug-in socket. Now the mains adapter delivered with the rechargeable battery must be applied.

6.5 Connection of peripheral devices

Before connecting or disconnecting of additional devices (printer, PC) to the data interface, always disconnect the balance from the power supply.

With your balance, only use accessories and peripheral devices by KERN, as they are ideally tuned to your balance.

6.6 Initial Commissioning

In order to obtain exact results with the electronic balances, your balance must have reached the operating temperature (see warming up time chap. 1). During this warming up time the balance must be connected to the power supply (mains, accumulator or battery).

The accuracy of the balance depends on the local acceleration of gravity. Strictly observe hints in chapter Adjustment.

6.7 Adjustment

As the acceleration value due to gravity is not the same at every location on earth, each balance must be coordinated - in compliance with the underlying physical weighing principle - to the existing acceleration due to gravity at its place of location (only if the balance has not already been adjusted to the location in the factory). This adjustment process must be carried out during the initial start-up, after change in location and variation of surrounding temperature. To receive accurate measuring values it is also recommended to adjust the balance periodically in weighing operation.

6.8 Adjustment

The adjustment should be made with the recommended adjustment weight (see chap. 1 "Technical data"). Adjustment is also possible with the weights of other nominal values (see table 1), but not the optimum for measuring technique.

Procedure when adjusting:

Observe stable environmental conditions. A warming up time (see chapter 1) is required for stabilization.

Switch on the balance using the  key

Press  key and keep it pressed, after the acoustic signal appears in the display for short time „**CAL**“. After that the exact size appears flashing in the display (chapter.8.4) of the adjustment weight.

Now set the adjusting weight in the centre of the weighing plate.

Now press the  key. Short time later appears „**CAL F**“, then return automatically to the normal weighing mode. In the display there appears the value of the adjustment weight.

An error during adjustment or the use of an incorrect adjusting weight will result in an error message „**CAL E**“. Repeat adjustment.

Keep the adjustment close to the balance. Daily control of the weighing exactness is recommended for quality-relevant applications.

7 Operation

7.1 Overview of display

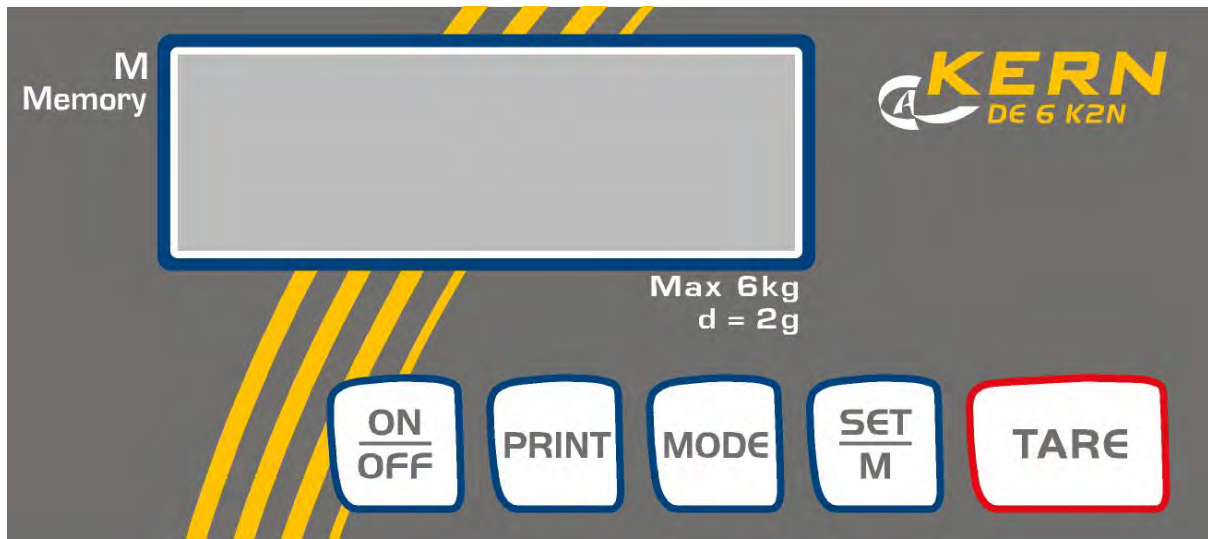

7.2 Weighing

Switch on the balance using the  key

The balance shows for approx. 3 seconds „88888“ in the display and then goes to „0“. Now it is ready for operation.

Important: Should the display flash or not be on „0“, press the  key.

Only now (!) place goods onto weighing plate. Take care that the weighed material does not touch the balance housing or the base mat.

Now the weight is displayed, after the standstill control appears the weighing unit (e.g. g or kg) right-hand in the display.

If the goods are heavier than the weighing range, the display will show "Error" (=Overload), and a whistle is sounded.

7.3 Taring

Switch-on the balance using the  key and wait for the „0“ display.

Put the tare vessel on the weighing plate and press the  key. The balance display goes to „0“. The weight of the container is now internally saved.

If after finishing the weighing process the  key, is pressed again, „0“ appears anew in the display.

The taring process can be repeated any number of times, e.g. when adding several components for a mixture (adding).

The limit is reached when the whole weighing range is exhausted.



After removing the taring container the total weight is displayed as negative display.



7.4 PRE-Tare function

Using this function the weight of a tare vessel can be stored.

This value also remains saved if the balance meanwhile has been switched off and switched on again.

Switch-on balance using the  key and wait for the „0“ display.

Put tare vessel on the weighing plate and press the  key 6 times until „PtArE“ flashes on the display. By actuating the  key, the current weight on the weighing plate is saved as PRE-Tare weight.

To switch off this function, unload the weighing plate and press the  key 6 times, until „PtArE“ flashes on the display. Then press the  key. The stored PRE-Tare weight is deleted.

7.5 Plus/minus weighings

For example unit weight control, fabrication control etc.

Switch-on the balance using the  key and wait for the „0“ display.

Put the nominal weight on the weighing plate and tare to „0“ using the  key.

Remove the nominal weight.

Put the test objects subsequently on the weighing plate, the respective deviation from the nominal weight is displayed with the respective sign to „+“ and „-“.

According to the same procedure also packages with the same weight can be produced, referring to a nominal weight.

Back to weighing mode by pressing the  key.

7.6 Parts counting

Switch-on the balance using the  key and wait for the „0“ display.

Press  key shortly.

Appears the reference unit number **5**.

By pressing the  key several times, more reference quantities **10**, **25** and **50** can be called up.

Place as many pieces to count on the weighing plate as the set reference quantity requires.

Confirm with  key.

The balance is now in parts counting mode counting all units on the weighing plate

By pressing the  key the balance returns to the weighing mode and displays the weight of the counted units.

Important: The larger the reference quantity, the more accurate the parts counting.

Smallest counted weight see table „**Technical data**“, if this weight is less, in the display appears „**Er 1**“. Use  key to return to weighing mode.

The tare vessels can also be used for piece counting. Prior to the piece count tare the tare vessel with  key.

7.7 Net-total weighings



It is useful if a mixture of several components is weighed into a tare vessel and finally the sum weight of all weighed components is necessary for control purposes (net-total, i.e. the weight of the tare vessel).

Example:

Switch-on the balance using the  key and wait for the „0“ display.

Put tare vessel onto weighing plate, tare with  key to „0“.

Weigh component **1** and tare with  key (Memory) to „0“. The memory activation is indicated by a triangle on the left border of the display.

Weigh component **2**, when pressing the  key appears the net-total, that means, the sum weight of the components **1** and **2**. Tare to „0“ using the  key.

Weigh component **3**, when pressing the  key, appears the net-total, i.e. the sum weight of components **1** and **2** and **3**.

If necessary, also fill the formula up to the desired final value.

Back to weighing mode by pressing the  key.

7.8 Percent weighings

Display symbol: %

Percent weighing allows to display weight in percent, in relation to a reference weight.

Switch-on the balance using the  key and wait for the „0“ display.

Press the  key several times shortly. The reference quantities of the counting function are passed through, after that „100%“ is displayed.

Place the reference item on the weighing pan.

Press  key, the weight of the item is taken over as reference (100%).

Now you can place the test objects onto the weighing plate; the percentage is displayed

Back to weighing mode by pressing the  key.

7.9 Weighing units (Unit)

Switch-on the balance using the  key and wait for the „0“ display.

Press the  key and keep it pressed until „UNIT“ appears on the display.







Press  shortly, the selected unit appears in the display.

Use the  key to select between the different units (see table).

By pressing the  key the selected weighing unit is taken over.

	<i>Display</i>	<i>Conversion factor</i> <i>1 g =</i>
Gram	g	1.
Pound	lb	0.0022046226
Unze	oz	0.035273962
Troy Unze	ozt	0.032150747
Tael Hongkong	tlh	0.02671725
Tael Taiwan	tlt	0.0266666
Grain	gn	15.43235835
Pennyweight	dwt	0.643014931
Momme	(mom)	0.2667
Tola	tol	0.0857333381
Carat	ct	5
Freely selectable factor *)	FFA	xx.xx

*)

In order to enter an own conversion factor, press the  key as explained above until „FFA“ is displayed. Press the  key to reach to the selection. The last digit begins to flash. Using the  key, the displayed value is increased by 1, with the  key it is reduced by 1. Use the  key to jump one digit to the left. When all the changes are ready, use the  key to save this value and by pressing the  key the „Freely selectable factor“ is taken over as current weighing unit.

The different weighing models have integrated different foreign weighing units. Details can be seen in this table:

Model												
Units	DE 3K1 N	DE 6K0.5 N	DE 6K2 N	DE 12K1 N	DE 15K0.5 N	DE 15K5 N	DE 24K2 N	DE 30K1 N	DE 36K10 N	DE 36K10 NL	DE 60K2 N	DE 60K5 N
Gram	X	X	X	X	X	X	X	X			X	X
Kilogram	X		X	X	X	X	X	X	X	X	X	X
Pound	X	X	X	X	X	X	X	X	X	X	X	X
Ounce	X	X	X	X	X	X	X	X	X	X	X	X
Troy ounce	X	X	X	X	X	X	X	X	X	X	X	X
Tael Hongkong	X	X	X	X	X	X	X	X	X	X	X	X
Tael Taiwan	X	X	X	X	X	X	X	X	X	X	X	X
Pennyweight	X	X	X	X	X	X	X	X			X	
Momme	X	X	X	X	X	X	X	X	X	X	X	X
Tola	X	X	X	X	X	X	X	X	X	X	X	X
Freely selectable Factor	X	X	X	X	X	X	X	X	X	X	X	X

Model												
Units	DE 60K5 NL	DE 60K20 N	DE 60K20 NL	DE 120K10 N	DE 120K10 NL	DE 150K5 N	DE 150K50 N	DE 150K50 NL	DE 150K50 NXL	DE 240K20NL	DE 300K100 N	DE 300K100 NL
Gram						X						
Kilogram	X	X	X	X	X	X	X	X	X	X	X	X
Pound	X	X	X	X	X	X	X	X	X	X	X	X
Ounce	X	X	X	X	X	X	X	X	X	X	X	X
Troy ounce	X	X	X	X	X	X	X	X	X	X	X	X
Tael Hongkong	X	X	X	X	X	X	X	X	X	X	X	X
Tael Taiwan	X	X	X	X	X	X	X	X	X	X	X	X
Pennyweight						X						
Momme	X	X	X	X	X	X				X		
Tola	X	X	X	X	X	X	X	X	X	X		
Freely selectable Factor	X	X	X	X	X	X	X	X	X	X	X	X

7.10 Display background illumination

In the menu the functions of the background illumination can be switched on or off. Proceed as follows:

Switch-on the balance using the  key and wait for the „0“ display.

Press the  key and keep it pressed until „UNIT“ appears on the display.

Press the  key seven times, in the display appears „bl“.

Confirm by pressing the  key

Use the  key to choose between the following settings:

Display	Adjustment	Function
„bl“ on	Background illumination on	Contrast-full display which can also be red in the darkness.
„bl“ off	Background illumination off	Battery saving
„bl“ Ch	The background illumination will be switched off automatically 10 sec after having reached a stable weighing value.	Battery saving

Use the  key to confirm your selected setting.

7.11 Animal weighing function

The balance has an integrated animal weighing function (mean value calculation). With this function it is possible to weigh domestic or small animals exactly, although they do not stand quiet on the weighing plate.

Note: If they move too much, an exact weighing will not be possible.

In the menu the animal weighing function can be switched on or off. To achieve this, follow the sequence of operations below:

Switch-on the balance using the  key and wait for the „0“ display.

Press the  key and keep it pressed until „UNIT“ appears on the display.

Press the  key eight times, in the display appears „ANL“.

Confirm by pressing the  key

Using the  key select one of the following settings:

Display	Function
„ANL“ Off	Animal weighing function is switched off
„ANL“ 3	Weighing value calculation above 3 sec. till to the value display
„ANL“ 5	Weighing value calculation above 5 sec. till to the value display
„ANL“ 10	Weighing value calculation above 10 sec. till to the value display
„ANL“ 15	Weighing value calculation above 15 sec. till to the value display

Confirm the selected setting using the  key.

Operation:

Switch-on the balance using the **ON** key and wait for the „0“ display.

Put the weighing good (animal) on the weighing plate and press the  key. In the display the preselected time is displayed in seconds and then is counted towards zero. During this time the balance takes up several measuring values. When reaching „0“ sounds an acoustic signal and the calculated weighing value is displayed.

By pressing the  key several times, the balance returns to the normal weighing mode.





Repeated pressing of the  key activates this function anew.

8 Settings

8.1 Call-up menu structure

Switch-on the balance using the  key and wait for the „0“ display.

To enter into the menu structure keep the  key pressed approx. 3 sec. until „UNIT“ appears.

By pressing the  key the different menu items are called up. Use the  key to select a menu item. Within this menu item use the  key to make your choice. If the  key is repeatedly actuated, the setting will be saved.

Press the PRINT key
3 seconds ->

Chapter 8.5.1
Data transfer mode

Chapter 8.6
Selection printed edition

Chapter 8.5.2
Baud rate

Chapter 6.4
Battery operation

Chapter 8.3
Zero-Tracking

Chapter 8.4
Selection of adjustment
weight

Chapter 7.10
Background illumination

Chapter 7.11
Animal weighing function

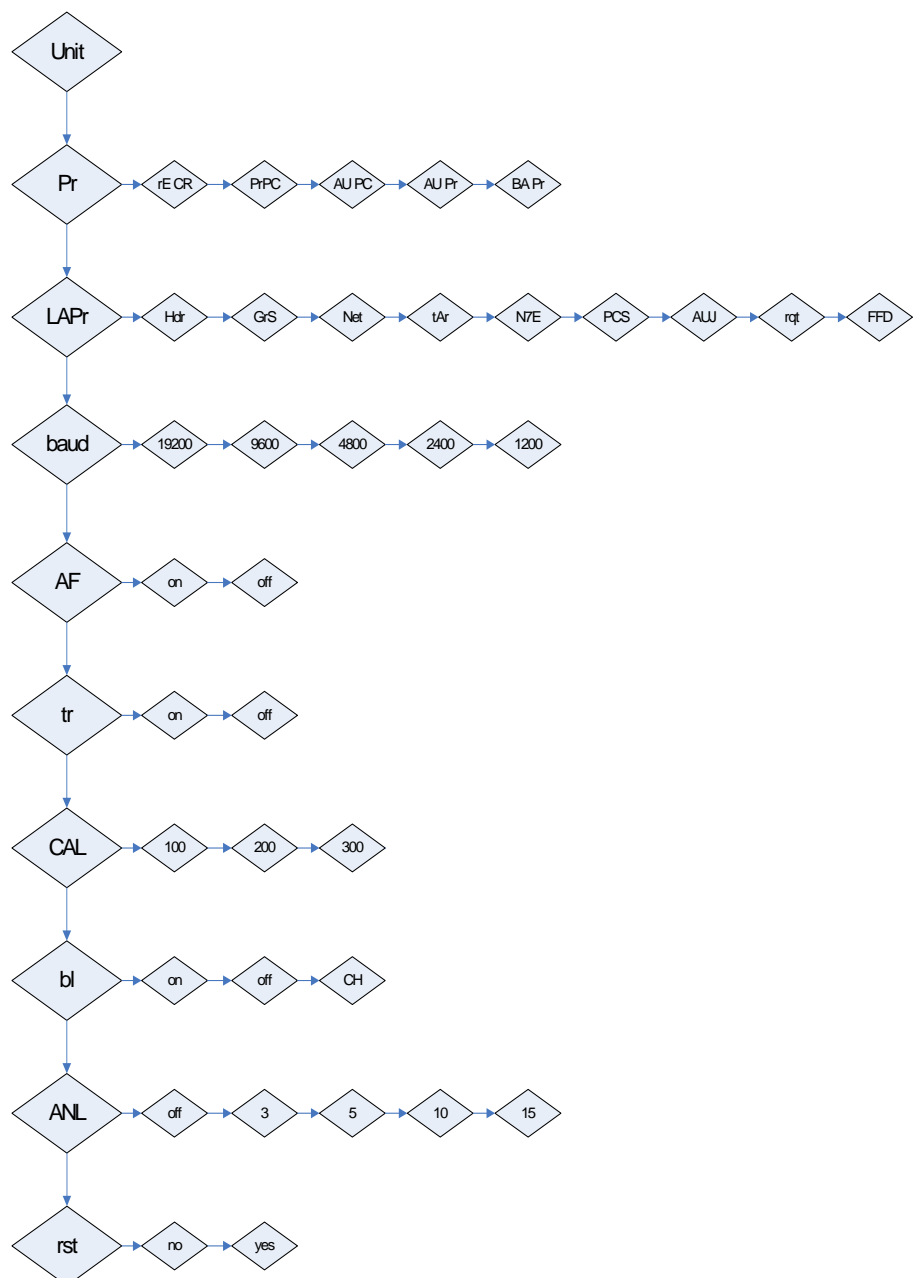

Chapter 8.7
Reset to
Default setting



8.2 Leave menu structure

Everywhere in the menu it is possible to leave the menu structure and thereby save or reject the changes made.

After pressing the  key „Exit“ is displayed.

A: Use the  (YES) key, to confirm. After that „store“ is displayed. If it shall be saved, press the  key repeatedly.

If the menu shall be left without saving,





press the  (NO) key.

B: The  (NOT EXIT) key must be pressed, if the next menu item shall be reached. After having set all the individual adjustments, it can be saved.

8.3 Dosing and Zero-tracking

The Auto-Zero function is used to tare small variations in weight automatically. In the event that small quantities are removed or added to the material to be weighed, incorrect weighing results can be displayed due to the “stability compensation“ in the balance. (Example: Slowly draining fluids from a container on the balance). When apportioning involves small variations of weight, it is advisable to switch off this function.

If **Zero-Tracking** however is switched off, the weighing display becomes more busy.

Activate/deactivate Zero-Tracking	Balance display
1. Keep the  key pressed until „Unit“ is displayed.	Unit
2. Press the  key several times until „tr“ is displayed.	tr
3. Press the  key to activate the function.	tr on
4. By pressing once more the  key, the function is deactivated.	tr off
5. The changed setting is taken over by pressing the  key.	
6. The balance returns to weighing mode.	0.0 g

8.4 Selection of the adjustment weight

In the model series KERN DE, the adjustment weight can be selected from three pre-set nominal values (approx. 1/3; 2/3; max) (refer also to table 1 below, factory setting with grey background). In order to achieve high-quality weighing results in the sense of the measuring technology, it is recommended to select the nominal value as high as possible.

Table 1:

DE3K1N	DE6K0.5N	DE6K2N	DE12K1N	DE15K0.5N
1000	2000	2000	4000	5000
2000	4000	4000	8000	10000
3000	6000	6000	12000	15000

DE15K5N	DE24K2N	DE30K1N	DE36K10N	DE36K10NL
5000	10000	10000	10000	10000
10000	15000	20000	20000	20000
15000	20000	30000	30000	30000

DE60K2N	DE60K5N	DE60K5NL	DE60K20N	DE60K20NL
20000	20000	20000	20000	20000
40000	40000	40000	40000	40000
60000	60000	60000	60000	60000

DE120K10N	DE120K10NL	DE150K5N	DE150K50N	DE150K50NL
40000	40000	50000	50000	50000
80000	80000	100000	100000	100000
120000	120000	150000	150000	150000

DE150K50NXL	DE240K20NL	DE300K100N	DE300K100NL
50000	100000	100000	100000
100000	150000	200000	200000
150000	200000	300000	300000





8.5 Interface RS232C

Data output via interface RS 232 C

General Information







The previous condition for the data transfer between balance and a peripheral device (e.g. printer, PC ...) is that the appliances are set to the same interface parameters (e.g. baud rate, transfer mode ...).

8.5.1 Data transfer mode

<i>Setting of data transfer mode</i>	<i>Balance display</i>
1. Keep the  key pressed until „Unit" is displayed.	Unit
2. Press  key, „Pr" appears.	Pr
3. To change the setting, press the  key.	Pr PC
4. The mode can be converted using the  key (Pr PC; AU PC; AU Pr ; re Cr ; BA Pr ; details chapter 9.4).	AU Pr
5. The changed setting is taken over by pressing the  key.	
6. The balance returns to weighing mode.	0.0 g

8.5.2 Baud rate

The baud rate necessary for the measuring values transfer can be set. In the following example the baud rate is set to 9600 baud.

<i>Setting of baud rate</i>	<i>Balance display</i>
1. Keep the  key pressed until „Unit" is displayed.	Unit
2. Press  key	Pr
3. Press  key, „baud" appears.	Baud
4. Confirm by pressing the  key	4800
5. The baud rate can be changed using the  key (1200, 2400, 4800, 9600 , 19200).	9600
6. The changed setting is taken over by pressing the  key.	
7. The balance returns to weighing mode.	0.0 g

8.6 Selection printed edition



Use this function to select which data are sent via the RS232C interface.
To achieve this, follow the sequence of operations below: (is **not** valid for the data transfer mode BAPr)

Switch-on the balance using the  key and wait for the „0“ display.



Press the  key and keep it pressed until „UNIT“ appears on the display.

Press the  key twice, in the display appears „LAPr“.

Confirm by pressing the  key

Now it is possible to scroll forward in the available edition parameters using the  key, to scroll backward, use the  key.

After actuating the  key, the current state is displayed (on / off).

Change status using the  or  key.

After that the current state is saved using the  key and the menu is left.

By that way the user can configurate his own data block, which then is sent to a printer or to a PC.

Display	Status	Function
„Hdr“	On / Off	Edition of the headlines
„GrS“	On / Off	Edition of the total weight
„Net“	On / Off	Edition of the net weight
„tAr“	On / Off	Edition of the tare weight
„N7E“	On / Off	Edition of the stored weight
„PCS“	On / Off	Edition of quantity
„AUJ“	On / Off	Edition of the unit weight
„rqt“	On / Off	Edition of the reference quantity
„FFd“	On / Off	Edition of a page feeding

8.7 Reset to factory setting

With this function the manual changes of the menu settings are reset to factory setting.

Switch-on balance using  key and wait for „0“ display.

Press the  key and keep it pressed until „UNIT“ appears on the display.

Press the  key nine times, in the display appears „rst“.

Confirm selection with  key. The current status „no“ is displayed.

Use the  key to set the status to „YES“.

When pressing the  key, a reset to factory setting is carried out, and at the same time the status is reset to „no“.

After that return to the weighing mode.

9 Data output RS 232 C

9.1 Technical data

- 8-bit ASCII Code
- 1 start bit, 8 data bits, 1 stop bit, no parity bit
- Baud rate selectable at 1200, 2400, 4800 and 9600 Baud
- Miniature plug-in necessary (9 pole D-Sub)
- For operation with interface faultless operation is only ensured with the correct KERN – interface cable (max. 2m)

9.2 Pin allocation of the balance output socket (front view)

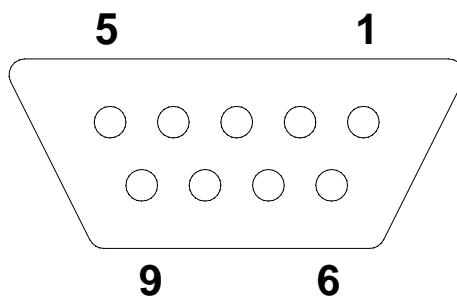

Pin 2: Transmit data
 Pin 3: Receive data
 Pin 5: Signal ground

9.3 Explanation of the data transfer

9.3.1 Pr PC

Press the PRINT key, at stable weight the format is transferred from **LAPR**.

a. Format for stable values for weight/quantity/percentage

1	2	3	4	5	6	7	8	9	10	11	12	13	14	15	16	17	18
B*	B	B	B	B	B	B	B	B	0	.	0	B	g	B	B	C	LF
																R	

b. Format in case of fault

1	2	3	4	5	6	7	8	9	10	11	12	13	14
B	B	B	B	B	B	B	E	r	r	o	r	CR	LF

9.3.2 AU Pr

As soon as the weighing value is stable, the format is automatically transferred from **LAPR**.

c. Format for stable values for weight/quantity/percentage

1	2	3	4	5	6	7	8	9	10	11	12	13	14	15	16	17	18
B*	B	B	B	B	B	B	B	B	0	.	0	B	g	B	B	C	LF
																R	

d. Format in case of fault

1	2	3	4	5	6	7	8	9	10	11	12	13	14
B	B	B	B	B	B	B	E	r	r	o	r	CR	LF

9.3.3 AU PC

The weighing values are sent automatically and continuously, no matter if the value is stable or unstable.

e. Format for stable values for weight/quantity/percentage

1	2	3	4	5	6	7	8	9	10	11	12	13	14	15	16	17	18
B*	B	B	B	B	B	B	B	B	0	.	0	B	g	B	B	C R	LF

f. Format in case of fault

1	2	3	4	5	6	7	8	9	10	11	12	13	14
B	B	B	B	B	B	B	E	r	r	o	r	CR	LF

g. Format for unstable values for weight/quantity/percentage

1	2	3	4	5	6	7	8	9	10	11	12	13	14	15
B*	B	B	B	B	B	B	B	B	0	.	0	B	CR	LF

9.3.4 rE Cr

The remote control commands s/w/t are sent from the remote control unit to the balance as ASCII code. After the balance having received the s/w/t commands, it will send the following data.

Take into account that the following remote control commands must be sent without a subsequent CR LF.

- s** Function: Stable weighing value for the weight is sent via the RS232 interface
- w** Function: Weighing value for the weight (stable or unstable) is sent via the RS232 interface
- t** Function: No data are sent, the balance carries out the tare function.

h. Format for stable values for weight/quantity/percentage

1	2	3	4	5	6	7	8	9	10	11	12	13	14	15	16	17	18
B*	B	B	B	B	B	B	B	B	0	.	0	B	g	B	B	C R	LF

i. Format in case of fault

1	2	3	4	5	6	7	8	9	10	11	12	13	14
B	B	B	B	B	B	B	E	r	r	o	r	CR	LF

j. Format for unstable values for weight/quantity/percentage

1	2	3	4	5	6	7	8	9	10	11	12	13	14	15
B*	B	B	B	B	B	B	B	B	0	.	0	B	CR	LF

SYMBOLS:

B*	= blank or M
B / 0 /.	= blank / weight values / decimal dot, depending on weighing value
g	= weight unit / unit / %
E, o, r	= ASCII code or "E, o, r"
CR	= carriage return symbol
LF	= line feed symbol

9.4 Output on bar code printer

The data transfer mode has to be set on „**BA Pr**“ (chapter 8.5.1).

As bar code printer a Zebra printer model LP2824 is provided.

Take into account that the output format of the balance is fixedly defined and cannot be changed.

The printer format is stored in the printer, i.e. in case of a failure the printer cannot be changed with a new one from factory, previously it is necessary that KERN installs the respective software.

The Zebra printer and the balance must be connected to the delivered interface cable when they are switched off.

After switching-on both appliances, and after reaching the status ready-for-operation, a label will be printed out when pressing the  key.

10 Service, maintenance, disposal

10.1 Cleaning

Before cleaning, please disconnect the appliance from the operating voltage.

Please do not use aggressive cleaning agents (solvents or similar agents), but a cloth dampened with mild soap suds. Ensure that no liquid penetrates into the device and wipe with a dry soft cloth.

Loose residue sample/powder can be removed carefully with a brush or manual vacuum cleaner.

Spilled weighing goods must be removed immediately.

10.2 Service, maintenance

The appliance may only be opened by trained service technicians who are authorized by KERN. Before opening, disconnect from power supply.

10.3 Disposal

Disposal of packaging and appliance must be carried out by operator according to valid national or regional law of the location where the appliance is used.

11 Instant help

In case of an error in the program process, briefly turn off the balance and disconnect from power supply. The weighing process must then be restarted from the beginning.

Help:

Fault

Possible cause

The displayed weight does not glow.

- *The balance is not switched on.*
- *The mains supply connection has been interrupted (mains cable not plugged in/faulty).*
- *Power supply interrupted.*

The displayed weight is permanently changing

-

- *Draught/air movement*
- *Table/floor vibrations*
- *The weighing plate is in contact with foreign matter.*
- *Electromagnetic fields / static charging (choose different location/switch off interfering device if possible)*

The weighing value is obviously wrong

- *The display of the balance is not at zero*
- *Adjustment is no longer correct.*
- *Great fluctuations in temperature.*
- *Electromagnetic fields / static charging (choose different location/switch off interfering device if possible)*

Should other error messages occur, switch balance off and then on again. If the error message remains, inform your specialist dealer.